







## 1,000 Watt 48 Volt, Single Output Power Supply with PFC and Parallel Functions

| UNIT CODE      | DESCRIPTION   |
|----------------|---|
| PS-RSP 1000-48 | 1,000 Watt, 48V, Single Output, Enclosed Power Supply with PFC and Parallel Functions |

| SPECIFICATIONS           |                  |   |
|--------------------------|------------------|---|
| Input                    | Output           | Approvals   |
| Universal<br>90 ~ 264VAC | +48VDC @ 0 ~ 21A |       |

### Features at a Glance:

- Universal AC Input for Worldwide Use
- AC Input Active Surge Current Limiting
- Output Voltage can be trimmed between 40-110% of the 48 Volt output (19.2V ~ 52.8V)
- Efficient (90%) & power density of 10.7 W/in<sup>3</sup>
- Active PFC circuit in compliance to EN61000-3-2
- Built-in: 5V/0.5A Auxiliary output (remote control); Remote ON-OFF control; Remote sense function
- Protections: Short circuit, Overload, Over voltage, Over temperature
- Forced air cooling by built-in DC fan
- Parallel function - current sharing up to 4 units
- DC OK signal
- Safety Standards: UL60950-1, TUV EN60950-1
- EMC: EN61204-3, heavy Industry level, criteria A  
- See following pages for complete EMC details
- Certificates: UL, CUL, TUV, CB and CE
- MBTF: 116.7K hours min. MIL-HDBK-217F (25°C)
- Case: 952B
- Weight: 4.29 lbs. (1.95 Kgs)
- Dimensions: 11.6" L x 5.0" W x 1.6" H  
295L x 127W x 41H mm
- 5 year warranty



PS-RSP1000-48 is a 1,000 Watt, 1U low profile, enclosed type, switching power supply with universal AC input and both parallel and PFC functions.

Standard features include: High power density of 10.7 W/in<sup>3</sup>; Output trim range 40%~110% of 48V; 90% efficiency, Active PFC function (PF>0.95). Parallel function allowing current sharing with up to 4 units totaling up to 4 kilowatts. Short circuit, Overload, Over Voltage and Over Temperature protection. Circuits include built-in 5V/0.5A auxiliary output for remote control; Remote ON-OFF control and Remote sense functions. 5 year warranty.

Ideal for industrial and military use. Typical applications include telecom/datacom/signal, instrumentation, factory automation, front-end power system, IC testing equipment or any application where space is limited and efficiency is required.

|          |     |           |
|----------|-----|-----------|
| Pricing: | 1+  | \$ 349.95 |
|          | 10+ | 299.50    |
|          | 25+ | 273.00    |

Release & Application Notes

POLLOCK INDUSTRIES, INC. 81 Butternut Road, White River, VT 05001  
toll-free 1-866-665-5434 (603) 888-2467 sales@pollock.biz



- Features :
  - Universal AC input / Full range
  - AC input active surge current limiting
  - Built-in 5V/0.5A auxiliary power
  - Built-in active PFC function, PF>0.95
  - Protections: Short circuit / Overload / Over voltage / Over temperature
  - Output voltage can be trimmed between 40 ~ 110% of the rated output voltage
  - Forced air cooling by built-in DC fan
  - High power density 10.7w/inch<sup>3</sup>
  - 1U low profile 41mm
  - Active current sharing up to 4000W(3+1) (Note.8)
  - DC OK Signal
  - Built-in remote ON-OFF control
  - Built-in remote sense function
  - 5 years warranty



## SPECIFICATION

| MODEL                 | RSP-1000-12                          | RSP-1000-15   | RSP-1000-24              | RSP-1000-27  | RSP-1000-48 |              |
|-----------------------|--------------------------------------|---|--------------------------|--|-------------|--------------|
| OUTPUT                | DC VOLTAGE                           | 12V   | 15V                      | 24V  | 27V         | 48V          |
|                       | RATED CURRENT                        | 60A   | 50A                      | 40A  | 37A         | 21A          |
|                       | CURRENT RANGE                        | 0 ~ 60A   | 0 ~ 50A                  | 0 ~ 40A  | 0 ~ 37A     | 0 ~ 21A      |
|                       | RATED POWER                          | 720W  | 750W                     | 960W   | 999W        | 1008W        |
|                       | RIPPLE & NOISE (max.) Note.2         | 150mVp-p  | 150mVp-p                 | 150mVp-p   | 150mVp-p    | 150mVp-p     |
|                       | VOLTAGE ADJ. RANGE                   | 10 ~ 13.5V  | 13.5 ~ 16.5V             | 20 ~ 26.4V   | 24 ~ 30V    | 43 ~ 55V     |
|                       | VOLTAGE TOLERANCE Note.3             | ±1.0%   | ±1.0%                    | ±1.0%  | ±1.0%       | ±1.0%        |
|                       | LINE REGULATION                      | ±0.5%   | ±0.5%                    | ±0.5%  | ±0.5%       | ±0.5%        |
|                       | LOAD REGULATION                      | ±0.5%   | ±0.5%                    | ±0.5%  | ±0.5%       | ±0.5%        |
|                       | SETUP, RISE TIME                     | 300ms, 50ms at full load  |                          |  |             |              |
| HOLD UP TIME (Typ.)   | 16ms/230VAC 16ms/115VAC at full load |   |                          |  |             |              |
| INPUT                 | VOLTAGE RANGE Note.5                 | 90 ~ 264VAC   | 127 ~ 370VDC             |  |             |              |
|                       | FREQUENCY RANGE                      | 47 ~ 63Hz   |                          |  |             |              |
|                       | POWER FACTOR (Typ.)                  | 0.95/230VAC   | 0.98/115VAC at full load |  |             |              |
|                       | EFFICIENCY (Typ.)                    | 83%   | 85%                      | 88%  | 88%         | 90%          |
|                       | AC CURRENT (Typ.)                    | 12A/115VAC  | 6A/230VAC                |  |             |              |
|                       | INRUSH CURRENT (Typ.)                | 25A/115VAC  | 40A/230VAC               |  |             |              |
| LEAKAGE CURRENT       | <2.0mA / 240VAC                      |   |                          |  |             |              |
| PROTECTION            | OVERLOAD                             | 105 ~ 125% rated output power<br>Protection type : Constant current limiting, recovers automatically after fault condition is removed   |                          |  |             |              |
|                       | OVER VOLTAGE                         | 13.8 ~ 16.8V  | 17 ~ 20.5V               | 27.6 ~ 32.4V   | 31 ~ 36.5V  | 56.6 ~ 66.2V |
|                       | OVER TEMPERATURE                     | 85°C ±5°C (TSW2) detect on heatsink of O/P diode; 75°C ±5°C (TSW1) detect on heatsink of power transistor<br>Protection type : Shut down o/p voltage, re-power on to recover  |                          |  |             |              |
| FUNCTION              | AUXILIARY POWER(AUX)                 | 5V @ 0.5A (+5%, -8%)  |                          |  |             |              |
|                       | REMOTE ON/OFF CONTROL Note.6         | Power on : short between on/off(pin6) & -S(pin2) on CN50  |                          | Power off : open between on/off(pin6) & -S(pin2) on CN50 |             |              |
|                       | DC OK SIGNAL                         | The TTL signal out, PSU turn on = 0 ~ 1V ; PSU turn off = 3.3 ~ 5.6V  |                          |  |             |              |
|                       | OUTPUT VOLTAGE TRIM Note.6           | Adjustment of output voltage is possible between 40 ~ 110% of rated output  |                          |  |             |              |
|                       | CURRENT SHARING(CS)Note.7            | Please refer to function manual   |                          |  |             |              |
| ENVIRONMENT           | WORKING TEMP.                        | -20 ~ +60°C (Refer to "Derating Curve")   |                          |  |             |              |
|                       | WORKING HUMIDITY                     | 20 ~ 90% RH non-condensing  |                          |  |             |              |
|                       | STORAGE TEMP., HUMIDITY              | -40 ~ +85°C, 10 ~ 95% RH  |                          |  |             |              |
|                       | TEMP. COEFFICIENT                    | ±0.02%/°C (0 ~ 50°C)  |                          |  |             |              |
|                       | VIBRATION                            | 10 ~ 500Hz, 2G 10min./1cycle, 60min. each along X, Y, Z axes  |                          |  |             |              |
| SAFETY & EMC (Note 4) | SAFETY STANDARDS                     | UL60950-1, TUV EN60950-1 approved   |                          |  |             |              |
|                       | WITHSTAND VOLTAGE                    | I/P-O/P:3KVAC I/P-FG:2KVAC O/P-FG:0.5KVAC   |                          |  |             |              |
|                       | ISOLATION RESISTANCE                 | I/P-O/P, I/P-FG, O/P-FG:100M Ohms / 500VDC / 25°C / 70% RH  |                          |  |             |              |
|                       | EMC EMISSION                         | Compliance to EN55022 (CISPR22), EN61000-3-2,-3   |                          |  |             |              |
| OTHERS                | EMC IMMUNITY                         | Compliance to EN61000-4-2,3,4,5,6,8,11, EN55024, EN61000-6-2, EN61204-3, heavy industry level, criteria A   |                          |  |             |              |
|                       | MTBF                                 | 116.75K hrs min. MIL-HDBK-217F (25°C)   |                          |  |             |              |
|                       | DIMENSION                            | 295*127*41mm (L*W*H)  |                          |  |             |              |
| NOTE                  | PACKING                              | 1.95Kg; 6pcs/12.7Kg/1.15CUFT  |                          |  |             |              |
|                       | NOTE                                 | 1. All parameters NOT specially mentioned are measured at 230VAC input, rated load and 25°C of ambient temperature.<br>2. Ripple & noise are measured at 20MHz of bandwidth by using a 12" twisted pair-wire terminated with a 0.1uf & 47uf parallel capacitor.<br>3. Tolerance : includes set up tolerance, line regulation and load regulation.<br>4. The power supply is considered a component which will be installed into a final equipment. The final equipment must be re-confirmed that it still meets EMC directives. For guidance on how to perform these EMC tests, please refer to "EMI testing of component power supplies." (as available on <a href="http://www.meanwell.com">http://www.meanwell.com</a> )<br>5. Derating may be needed under low input voltages. Please check the derating curve for more details.<br>6. The power supply unit will have no output if the shorting connector is not assembled. It contains two shorting wires: one is from on/off(pin6) to -s(pin2) and the other is from Vco(pin8) to Vca(pin10). Please refer to function manual for details.<br>7. In parallel connection, maybe only one unit operate if the total output load is less than 5% of rated load condition.<br>8. Please consult MEAN WELL for applications of more units connecting in parallel. |                          |  |             |              |

**Mechanical Specification**

Case No. 952B Unit:mm

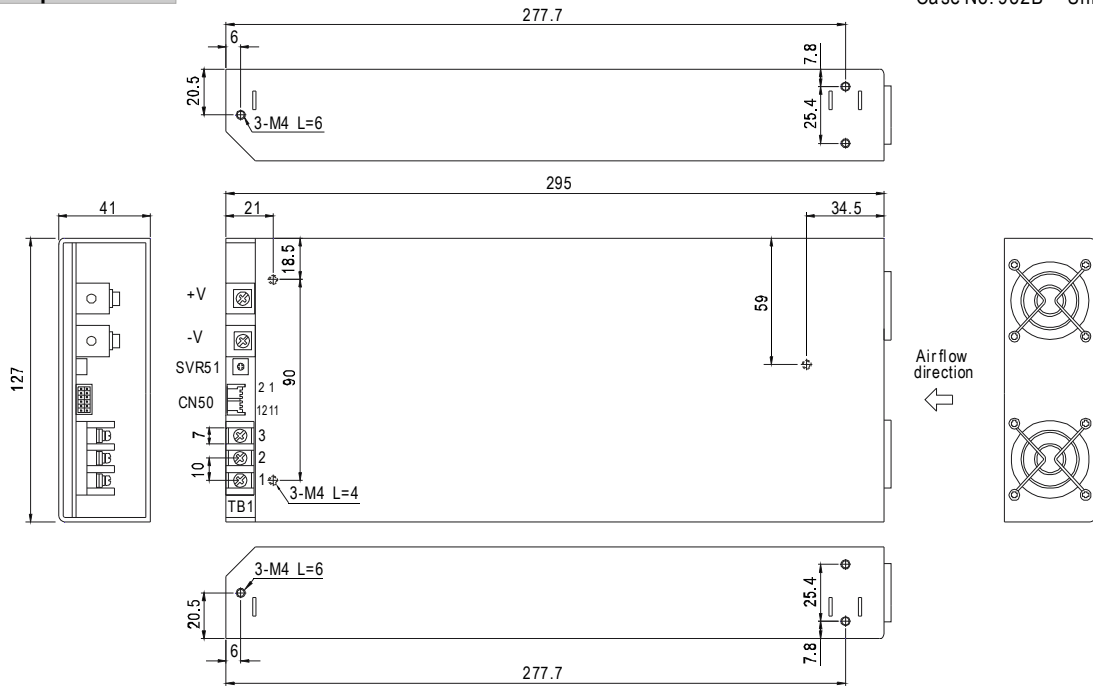

AC Input Terminal  
Pin No. Assignment

| Pin No. | Assignment |
|---------|------------|
| 1       | AC/N       |
| 2       | AC/L       |
| 3       | FG $\perp$ |

Control Pin No. Assignment (CN50) : HRS DF11-12DP-2DS or equivalent

| Pin No. | Assignment | Pin No. | Assignment | Pin No. | Assignment | Mating Housing              | Terminal                    |
|---------|------------|---------|------------|---------|------------|-----------------------------|-----------------------------|
| 1       | +S         | 5       | DC-OK      | 9       | Vci        | HRS DF11-12DS or equivalent | HRS DF11-12DS or equivalent |
| 2       | -S         | 6       | ON/OFF     | 10      | Vca        |                             |                             |
| 3       | G-AUX      | 7       | CS         | 11,12   | GND        |                             |                             |
| 4       | 5V-AUX     | 8       | Vco        |         |            |                             |                             |

**Block Diagram**

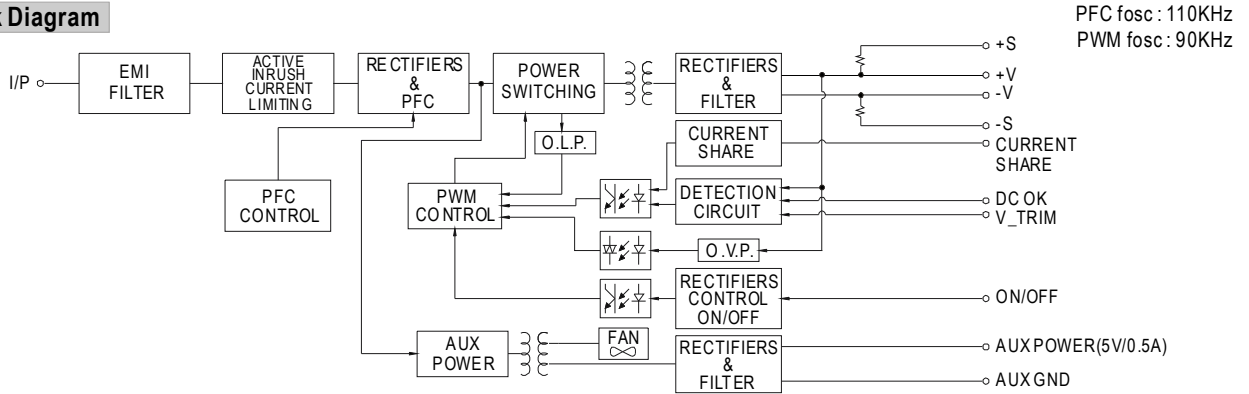

**Derating Curve**

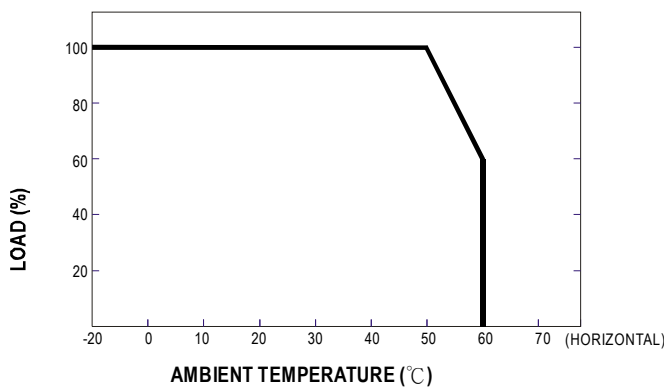

**Static Characteristics**

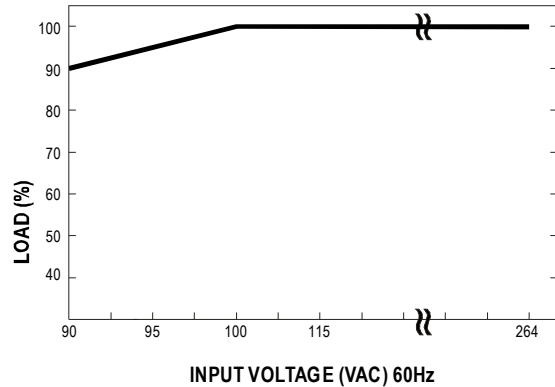

■ **Function Description of CN50**

| Pin No. | Function        | Description   |
|---------|-----------------|---|
| 1       | +S              | Positive sensing. The +S signal should be connected to the positive terminal of the load. The +S and -S leads should be twisted in pair to minimize noise pick-up effect. The maximum line drop compensation is 0.5V. |
| 2       | -S              | Negative sensing. The -S signal should be connected to the negative terminal of the load. The -S and +S leads should be twisted in pair to minimize noise pick-up effect. The maximum line drop compensation is 0.5V. |
| 3       | G-AUX           | Auxiliary voltage output ground. The signal return is isolated from the output terminals (+V & -V).   |
| 4       | 5V-AUX          | Auxiliary voltage output, 4.6~5.25V, referenced to pin 3(G-AUX). The maximum load current is 0.5A. This output has the built-in oring diodes and is not controlled by the "remote ON/OFF control".                    |
| 5       | DC_OK           | Open collector signal, referenced to pin11,12(GND). Low when PSU turns on. The maximum sink current is 10mA and the maximum external voltage is 5.6V.   |
| 6       | ON/OFF          | Turns the output on and off by electrical or dry contact between pin 6 ( ON/OFF) and pin 2 (-S). Short: Power ON, Open: Power OFF.  |
| 7       | CS              | Current sharing signal. When units are connected in parallel, the CS pins of the units should be connected to allow current balance between units.  |
| 8       | V <sub>co</sub> | Short connecting between V <sub>co</sub> (pin8) and V <sub>ca</sub> (pin10) if output voltage trim function is not used.  |
| 9       | V <sub>ci</sub> | Connect to external DC voltage source for output voltage trimming, referenced to pin 2 (-S). Output voltage can be trimmed between 40 ~ 110% of the rated output voltage.   |
| 10      | V <sub>ca</sub> | Connect to external resistor (1/8W) for output voltage trimming. Output voltage can be trimmed between 40 ~ 110% of the rated output voltage. Please refer to function manual for details.                            |
| 11,12   | GND             | These pins connect to the negative terminal (-V). Return for DC_OK Signal output.   |

■ **Function Manual**

**1. "Remote ON/OFF" and "Output voltage trim" functions are not used.**

The power supply unit will have no output if the shorting connector (accessory comes along with the PSU) is not assembled. It contains two shorting wires : one is from ON/OFF (pin6) to -S (pin2) and the other is from V<sub>co</sub> (pin8) to V<sub>ca</sub> (pin10).

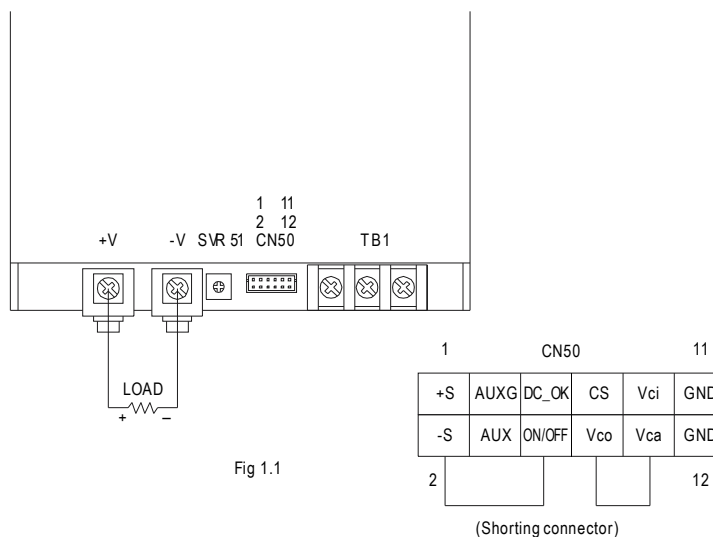

**2.Remote ON/OFF**

The PSU can be turned ON/OFF by using the "Remote ON/OFF" function

| Between ON/OFF(pin6) and -S(pin2) | Output Status |
|-----------------------------------|---------------|
| SW ON (Short)                     | ON            |
| SW OFF (Open)                     | OFF           |

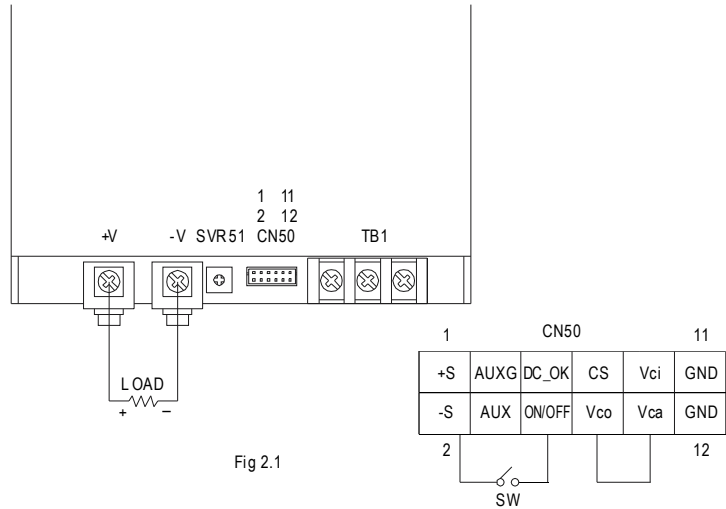

**3.DC\_OK signal**

"DC\_OK" is an open collector signal. It indicates the output status of the PSU. It can operate in two ways : One is sinking current from external TTL signal ; the other is sending out a TTL voltage signal.

**3-1 Sink current :**

The maximum sink current is 10mA and the maximum external voltage is 5.6V.

**3-2 TTL voltage signal :**

| Between DC- OK(pin5) and GND(pin11&12) | Output Status |
|--|---------------|
| 0 ~ 1V                                 | ON            |
| 3.3 ~ 5.6V                             | OFF           |

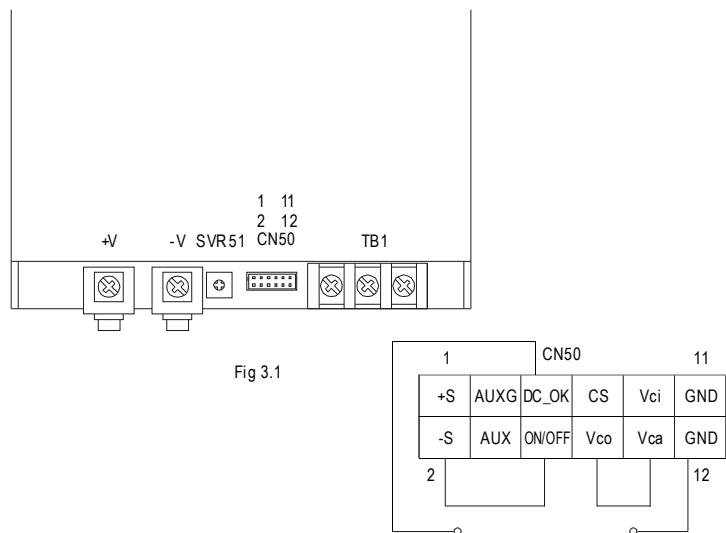

**4.Remote Sense**

The remote sensing compensates voltage drop on the load wiring up to 0.5V.

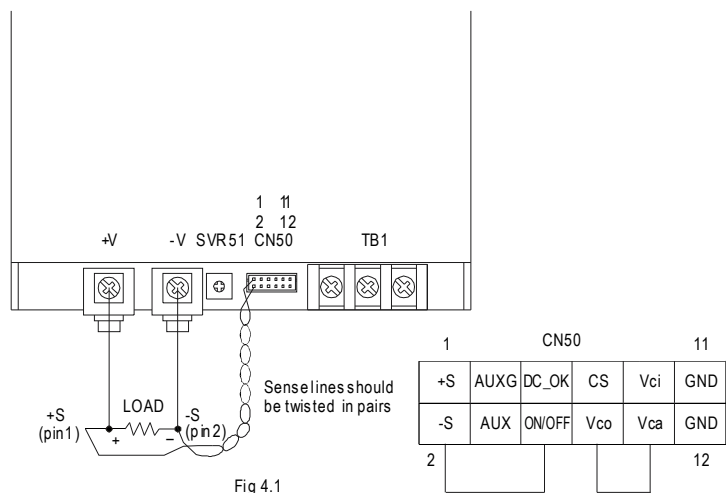

**5. Output Voltage TRIM**

Output voltage of RSP-1000 can be trimmed between 40% ~ 110% of its rated value by the following methods and +S & +V, -S & -V also need to be connected on CN50:

(1) Using external voltage source between "Vci"(pin9) and "-S"(pin2) that is shown in Fig5.1

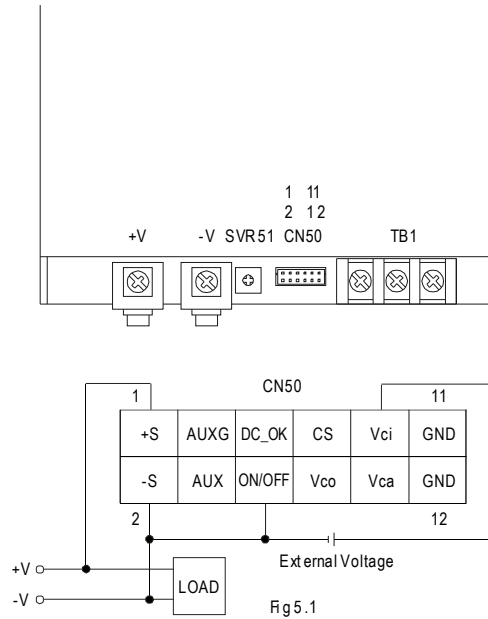
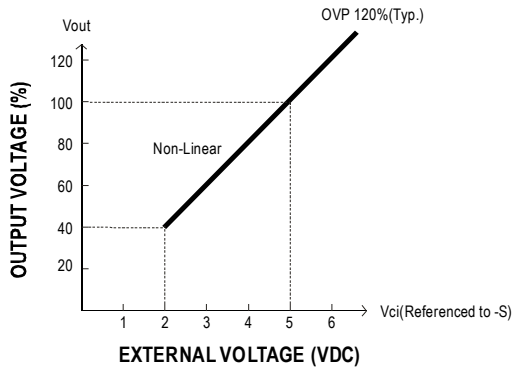

(2) Connecting a resistor externally that in shown in Fig 5.2 & Fig 5.3  
(A) O/P voltage goes down

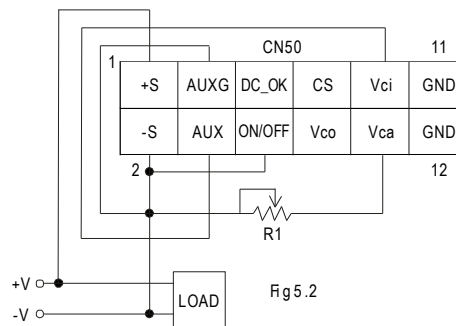
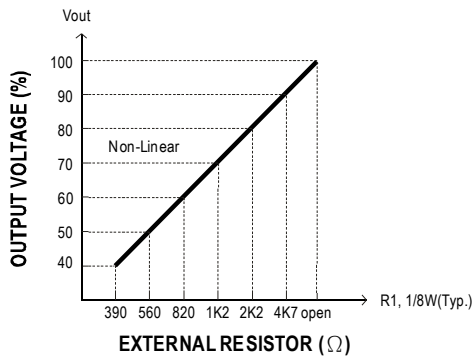

(B) O/P voltage goes up

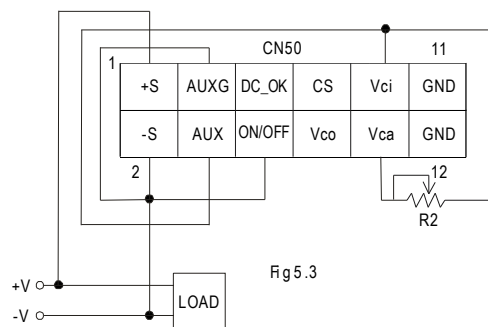
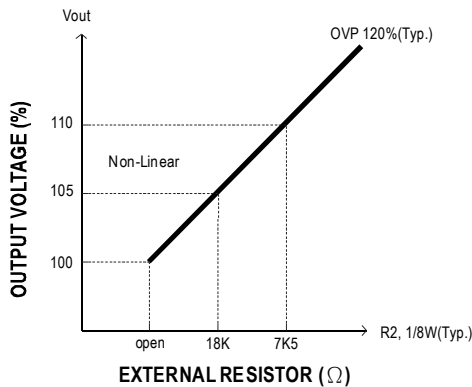

**6. Current Sharing with Remote Sensing**

RSP-1000 has the built-in active current sharing function and can be connected in parallel to provide higher output power :

- (1) Parallel operation is available by connecting the units shown as below.  
(+S, -S and CS are connected mutually in parallel).
- (2) Difference of output voltages among parallel units should be less than 0.2V.
- (3) The total output current must not exceed the value determined by the following equation.  
(output current at parallel operation)=(Rated current per unit)×(Number of unit)×0.9
- (4) In parallel operation 4 units is the maximum, please consult the manufacturer for applications of more connecting in parallel.
- (5) The power supplies should be paralleled using short and large diameter wiring and then connected to the load.

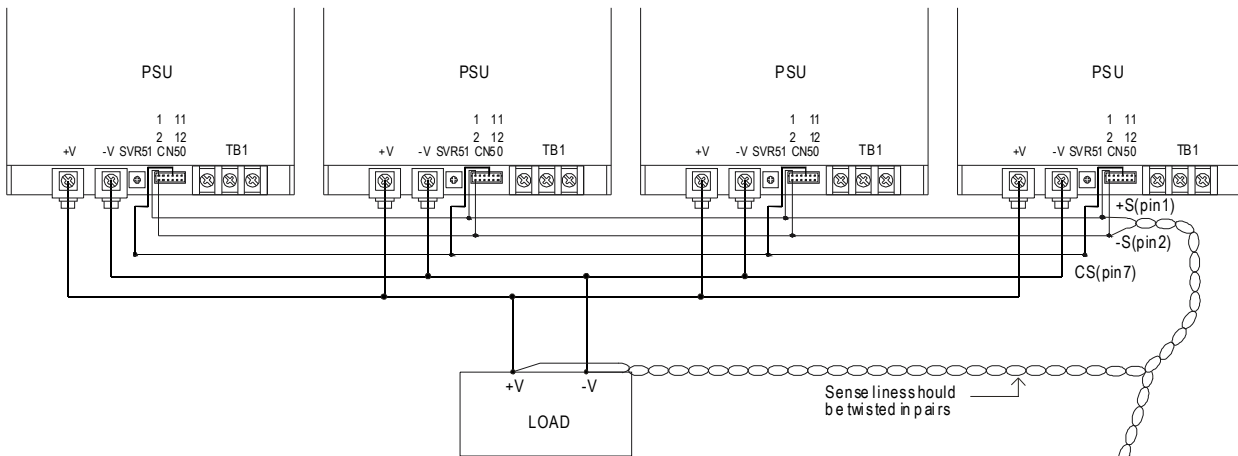
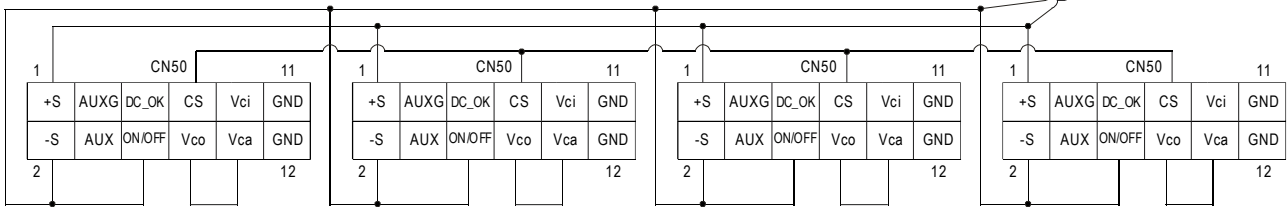

Fig 6.1



Note : In parallel connection, maybe only one unit (master) operate if the total output load is less than 5% of rated load condition. The other PSUs (slaves) may go into standby mode and their output LEDs will not turn on.